

**PHYSICS**

**SECTION-A**

1. Given below are two statement : one is labelled as Assertion A and the other is labelled as Reason R.

Assertion A : When a rod lying freely is heated, no thermal stress is developed in it.

Reason R : On heating the length of the rod increases.

In the light of the above statements, choose the correct answer from the options given below:

- (1) Both A and R are true but R is NOT the correct explanation of A
- (2) A is false but R is true
- (3) A is true but R is false
- (4) Both A and R are true and R is the correct explanation of A

2. A student is performing the experiment of resonance column. The diameter of the column tube is 6 cm. The frequency of the tuning fork is 504 Hz. Speed of the sound at the given temperature is 336 m/s. The zero of the meter scale coincides with the top end of the resonance column tube. The reading of the water level in the column when the first resonance occurs is:

- (1) 13 cm
- (2) 16.6 cm
- (3) 18.4 cm
- (4) 14.8 cm

3. Two satellites A and B of masses 200kg and 400kg are revolving round the earth at height of 600 km and 1600 km respectively. If  $T_A$  and  $T_B$  are the time periods of A and B respectively then the value of  $T_B - T_A$ :

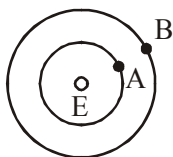

[Given : radius of earth = 6400km, mass of earth =  $6 \times 10^{24}$  kg]

- (1)  $1.33 \times 10^3$  s
- (2)  $3.33 \times 10^2$  s
- (3)  $4.24 \times 10^3$  s
- (4)  $4.24 \times 10^2$  s

4. The angular frequency of alternating current in a L-C-R circuit is 100 rad/s. The components connected are shown in the figure. Find the value of inductance of the coil and capacity of condenser.

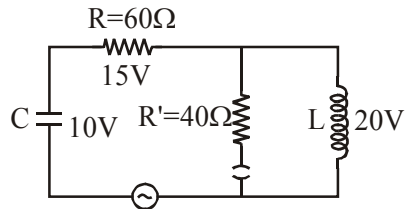

- (1) 0.8 H and 150  $\mu$ F
- (2) 0.8 H and 250  $\mu$ F
- (3) 1.33 H and 250  $\mu$ F
- (4) 1.33 H and 150  $\mu$ F

5. A proton, a deuteron and an  $\alpha$  particle are moving with same momentum in a uniform magnetic field. The ratio of magnetic forces acting on them is \_\_\_\_\_ and their speed is \_\_\_\_\_ in the ratio.

- (1) 1 : 2 : 4 and 2 : 1 : 1
- (2) 2 : 1 : 1 and 4 : 2 : 1
- (3) 4 : 2 : 1 and 2 : 1 : 1
- (4) 1 : 2 : 4 and 1 : 1 : 2

6. Given below are two statement : Statement-I: A speech signal of 2 kHz is used

to modulate a carrier signal of 1 MHz. The band width requirement for the signal is 4 kHz.

Statement-II : The side band frequencies are 1002 kHz. and 998 kHz.

In the light of the above statements, choose the correct answer from the options given below:

- (1) Statement I is true but Statement II is false
- (2) Statement I is false but Statement II is true
- (3) Both Statement I and Statement II are true
- (4) Both Statement I and Statement II are false

7. If the time period of a two meter long simple pendulum is 2s, the acceleration due to gravity at the place where pendulum is executing S.H.M. is :

- (1)  $\pi^2 \text{ms}^{-2}$  (2)  $9.8 \text{ ms}^{-2}$   
 (3)  $2\pi^2 \text{ms}^{-2}$  (4)  $16 \text{ m/s}^2$

8. The pitch of the screw gauge is 1mm and there are 100 divisions on the circular scale. When nothing is put in between the jaws, the zero of the circular scale lies 8 divisions below the reference line. When a wire is placed between the jaws, the first linear scale division is clearly visible while 72<sup>nd</sup> division on circular scale coincides with the reference line. The radius of the wire is

- (1) 1.64 mm (2) 0.82 mm  
 (3) 1.80 mm (4) 0.90 mm

9. A 5V battery is connected across the points X and Y. Assume  $D_1$  and  $D_2$  to be normal silicon diodes. Find the current supplied by the battery if the +ve terminal of the battery is connected to point X.

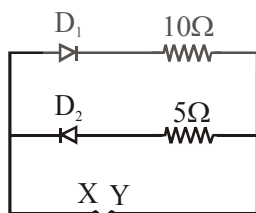

- (1) ~ 0.5 A (2) ~ 1.5 A  
 (3) ~ 0.86 A (4) ~ 0.43 A

10. An  $\alpha$  particle and a proton are accelerated from rest by a potential difference of 200 V. After this, their de Broglie wavelengths are  $\lambda_\alpha$  and

$\lambda_p$  respectively. The ratio  $\frac{\lambda_p}{\lambda_\alpha}$  is :

- (1) 3.8 (2) 8 (3) 7.8 (4) 2.8

11. A diatomic gas, having  $C_p = \frac{7}{2}R$  and  $C_v = \frac{5}{2}R$ , is heated at constant pressure. The

ratio  $dU : dQ : dW$  :

- (1) 5 : 7 : 3 (2) 5 : 7 : 2  
 (3) 3 : 7 : 2 (4) 3 : 5 : 2

12. An engine of a train, moving with uniform acceleration, passes the signal-post with velocity  $u$  and the last compartment with velocity  $v$ . The velocity with which middle point of the train passes the signal post is:

- (1)  $\sqrt{\frac{v^2 + u^2}{2}}$  (2)  $\frac{v - u}{2}$   
 (3)  $\frac{u + v}{2}$  (4)  $\sqrt{\frac{v^2 - u^2}{2}}$

13. Match List-I with List-II :

- | List-I                       | List-II                      |
|------------------------------|------------------------------|
| (a) $h$ (Planck's constant)  | (i) $[M L T^{-1}]$           |
| (b) $E_c$ (kinetic energy)   | (ii) $[M L^2 T^{-1}]$        |
| (c) $V$ (electric potential) | (iii) $[M L^2 T^{-2}]$       |
| (d) $P$ (linear momentum)    | (iv) $[M L^2 I^{-1} T^{-3}]$ |

Choose the correct answer from the options given below :

- (1) (a)→(iii), (b)→(iv), (c)→(ii), (d)→(i)  
 (2) (a)→(ii), (b)→(iii), (c)→(iv), (d)→(i)  
 (3) (a)→(i), (b)→(ii), (c)→(iv), (d)→(iii)  
 (4) (a)→(iii), (b)→(ii), (c)→(iv), (d)→(i)

14. Magnetic fields at two points on the axis of a circular coil at a distance of 0.05m and 0.2 m from the centre are in the ratio 8 : 1. The radius of coil is \_\_\_\_\_.

- (1) 0.2 m (2) 0.1 m  
 (3) 0.15 m (4) 1.0 m

15. A solid sphere of radius  $R$  gravitationally attracts a particle placed at  $3R$  from its centre with a force  $F_1$ . Now a spherical cavity of radius  $\left(\frac{R}{2}\right)$  is made in the sphere (as shown in figure) and the force becomes  $F_2$ . The value of  $F_1 : F_2$  is :

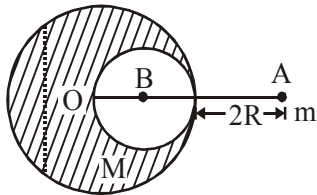

- (1) 25 : 36                      (2) 36 : 25  
 (3) 50 : 41                      (4) 41 : 50

16. Two radioactive substances X and Y originally have  $N_1$  and  $N_2$  nuclei respectively. Half life of X is half of the half life of Y. After three half lives of Y, number of nuclei of both are equal.

The ratio  $\frac{N_1}{N_2}$  will be equal to :

- (1)  $\frac{1}{8}$                                       (2)  $\frac{3}{1}$   
 (3)  $\frac{8}{1}$                                       (4)  $\frac{1}{3}$

17. In an octagon ABCDEFGH of equal side, what is the sum of

$$\overline{AB} + \overline{AC} + \overline{AD} + \overline{AE} + \overline{AF} + \overline{AG} + \overline{AH}$$

if,  $\overline{AO} = 2\hat{i} + 3\hat{j} - 4\hat{k}$

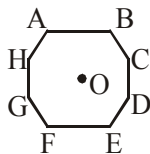

- (1)  $-16\hat{i} + 24\hat{j} + 32\hat{k}$   
 (2)  $16\hat{i} + 24\hat{j} - 32\hat{k}$   
 (3)  $16\hat{i} + 24\hat{j} + 32\hat{k}$   
 (4)  $16\hat{i} + 24\hat{j} + 32\hat{k}$  2)

18. Given below are two statements : one is labelled as Assertion A and the other is labelled as Reason R.

Assertion A : The escape velocities of planet A and B are same. But A and B are of unequal mass.

Reason R : The product of their mass and radius must be same,  $M_1R_1 = M_2R_2$

In the light of the above statements, choose the most appropriate answer from the options given below :

- (1) Both A and R are correct but R is NOT the correct explanation of A  
 (2) A is correct but R is not correct  
 (3) Both A and R are correct and R is the correct explanation of A  
 (4) A is not correct but R is correct

19. The current (i) at time  $t = 0$  and  $t = \infty$  respectively for the given circuit is :

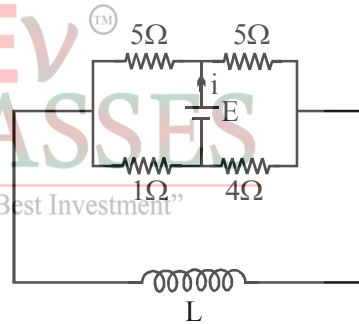

- (1)  $\frac{18E}{55}, \frac{5E}{18}$                       (2)  $\frac{10E}{33}, \frac{5E}{18}$   
 (3)  $\frac{5E}{18}, \frac{18E}{55}$                       (4)  $\frac{5E}{18}, \frac{10E}{33}$

20. Two coherent light sources having intensity in the ratio  $2x$  produce an interference pattern.

The ratio  $\frac{I_{\max} - I_{\min}}{I_{\max} + I_{\min}}$  will be :

- (1)  $\frac{2\sqrt{2x}}{x+1}$                                       (2)  $\frac{\sqrt{2x}}{2x+1}$   
 (3)  $\frac{\sqrt{2x}}{x+1}$                                       (4)  $\frac{2\sqrt{2x}}{2x+1}$

## SECTION-B

1. A transmitting station releases waves of wavelength 960 m. A capacitor of  $2.56 \mu\text{F}$  is used in the resonant circuit. The self inductance of coil necessary for resonance is  $\text{---} \times 10^{-8} \text{ H}$ .

2. The electric field in a region is given

$$\vec{E} = \left( \frac{3}{5} E_0 \hat{i} + \frac{4}{5} E_0 \hat{j} \right) \frac{N}{C}. \text{ The ratio of flux of}$$

reported field through the rectangular surface of area  $0.2 \text{ m}^2$  (parallel to  $y - z$  plane) to that of the surface of area  $0.3 \text{ m}^2$  (parallel to  $x - z$  plane) is  $a : b$ , where  $a = \text{---}$ .

[Here  $\hat{i}, \hat{j}$  and  $\hat{k}$  are unit vectors along  $x, y$  and  $z$ -axes respectively]

3. In a certain thermodynamical process, the pressure of a gas depends on its volume as  $kV^3$ . The work done when the temperature changes from  $100^\circ\text{C}$  to  $300^\circ\text{C}$  will be  $\text{---} nR$ , where  $n$  denotes number of moles of a gas.

4. A small bob tied at one end of a thin string of length  $1\text{m}$  is describing a vertical circle so that the maximum and minimum tension in the string are in the ratio  $5 : 1$ . The velocity of the bob at the height position is  $\text{---} \text{ m/s}$ .

(Take  $g = 10 \text{ m/s}^2$ )

5. In the given circuit of potentiometer, the potential difference  $E$  across  $AB$  ( $10\text{m}$  length) is larger than  $E_1$  and  $E_2$  as well. For key  $K_1$  (closed), the jockey is adjusted to touch the wire at point  $J_1$  so that there is no deflection in the galvanometer. Now the first battery ( $E_1$ ) is replaced by second battery ( $E_2$ ) for working by making  $K_1$  open and  $K_2$  closed. The galvanometer gives then null deflection at  $J_2$ .

The value of  $\frac{E_1}{E_2}$  is  $\frac{a}{b}$ , where  $a = \text{---}$ .

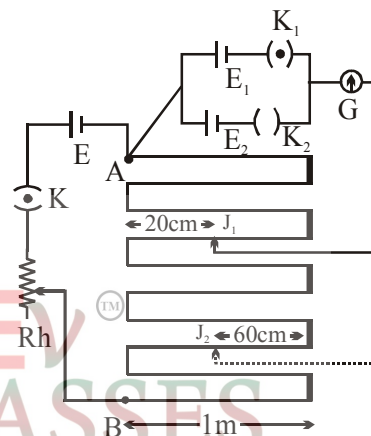

6. The same size images are formed by a convex lens when the object is placed at  $20\text{cm}$  or at  $10\text{cm}$  from the lens. The focal length of convex lens is  $\text{---} \text{ cm}$ .

7. 512 identical drops of mercury are charged to a potential of  $2\text{V}$  each. The drops are joined to form a single drop. The potential of this drop is  $\text{---} \text{ V}$ .

8. A coil of inductance  $2\text{H}$  having negligible resistance is connected to a source of supply whose voltage is given by  $V = 3t$  volt. (where  $t$  is in second). If the voltage is applied when  $t = 0$ , then the energy stored in the coil after  $4\text{s}$  is  $\text{---} \text{ J}$ .

9. A monoatomic gas of mass 4.0 u is kept in an insulated container. Container is moving with velocity 30 m/s. If container is suddenly stopped then change in temperature of the gas ( $R =$  gas constant) is  $\frac{x}{3R}$ . Value of x is \_\_\_\_.

10. The potential energy ( $U$ ) of a diatomic molecule is a function dependent on  $r$  (interatomic distance) as

$$U = \frac{\alpha}{r^{10}} - \frac{\beta}{r^5} - 3$$

where,  $\alpha$  and  $\beta$  are positive constants. The equilibrium distance between two atoms will be

$$\left(\frac{2\alpha}{\beta}\right)^{\frac{a}{b}}, \text{ where } a = \text{____}.$$



# CHEMISTRY

## SECTION-A

1. Given below are two statements:

Statement I :  $\text{CeO}_2$  can be used for oxidation of aldehydes and ketones.

Statement II : Aqueous solution of  $\text{EuSO}_4$  is a strong reducing agent.

In the light of the above statements, choose the correct answer from the options given below:

- (1) Statement I is false but statement II is true
- (2) Statement I is true but statement II is false
- (3) Both statement I and statement II are true
- (4) Both statement I and statement II are false

2. According to molecular theory, the species among the following that does not exist is:

- (1)  $\text{He}_2^+$     (2)  $\text{He}_2^-$     (3)  $\text{Be}_2$     (4)  $\text{O}_2^{2-}$

3. Which of the following reaction/s will not give p-aminoazobenzene?

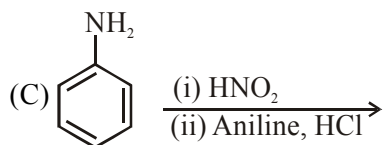
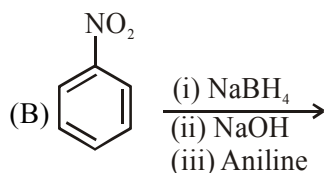
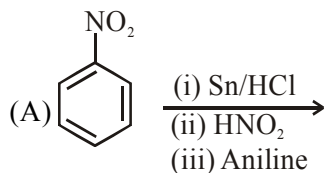

- (1) A only                      (2) B only  
(3) C only                      (4) A and B

4. Which of the following equation depicts the oxidizing nature of  $\text{H}_2\text{O}_2$ ?

- (1)  $\text{KIO}_4 + \text{H}_2\text{O}_2 \rightarrow \text{KIO}_3 + \text{H}_2\text{O} + \text{O}_2$
- (2)  $2\text{I}^- + \text{H}_2\text{O}_2 + 2\text{H}^+ \rightarrow \text{I}_2 + 2\text{H}_2\text{O}$
- (3)  $\text{I}_2 + \text{H}_2\text{O}_2 + 2\text{OH}^- \rightarrow 2\text{I}^- + 2\text{H}_2\text{O} + \text{O}_2$
- (4)  $\text{Cl}_2 + \text{H}_2\text{O}_2 \rightarrow 2\text{HCl} + \text{O}_2$

5. Identify A in the given chemical reaction.

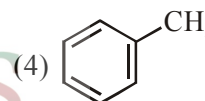
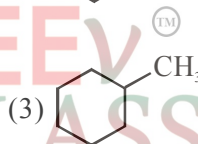
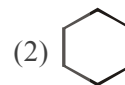
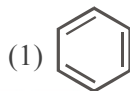
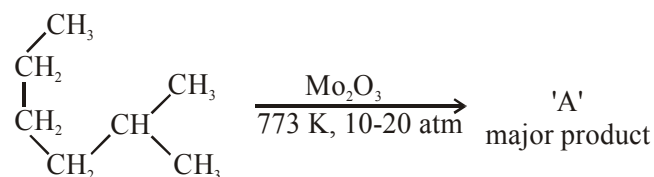

“Knowledge Is The Best Investment”

6. Complete combustion of 1.80 g of an oxygen containing compound ( $\text{C}_x\text{H}_y\text{O}_z$ ) gave 2.64 g of  $\text{CO}_2$  and 1.08 g of  $\text{H}_2\text{O}$ . The percentage of oxygen in the organic compound is:

- (1) 51.63    (2) 63.53    (3) 53.33    (4) 50.33

7. Which one of the following reactions will not form acetaldehyde?

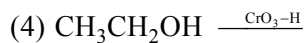
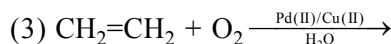
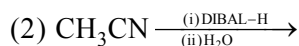
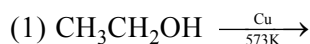

8. The correct statement about  $B_2H_6$  is:
- (1) Terminal B–H bonds have less p-character when compared to bridging bonds.
  - (2) The two B–H–B bonds are not of same length
  - (3) All B–H–B angles are of  $120^\circ$
  - (4) Its fragment,  $BH_3$ , behaves as a Lewis base
9. The plots of radial distribution functions for various orbitals of hydrogen atom against 'r' are given below:

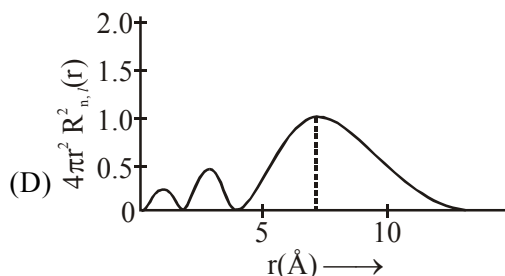
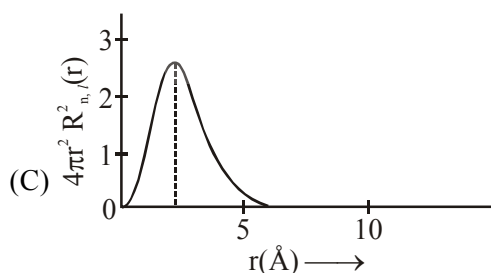
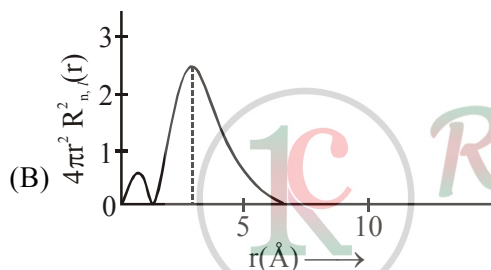
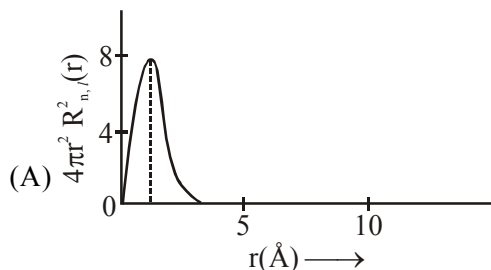

The correct plot for 3s orbital is:

- (1) (B)
- (2) (A)
- (3) (D)
- (4) (C)

10. Given below are two statements:  
 Statement I : An allotrope of oxygen is an important intermediate in the formation of reducing smog.  
 Statement II : Gases such as oxides of nitrogen and sulphur present in troposphere contribute to the formation of photochemical smog. In the light of the above statements, choose the correct answer from the options given below:
- (1) Both statement I and Statement II are false
  - (2) Statement I is true but Statement II is false
  - (3) Both Statement I and Statement II are true
  - (4) Statement I is false but Statement II is true
11. In which of the following pairs, the outer most electronic configuration will be the same?

- (1)  $Cr^+$  and  $Mn^{2+}$
- (2)  $Ni^{2+}$  and  $Cu^+$
- (3)  $Fe^{2+}$  and  $Co^+$
- (4)  $V^{2+}$  and  $Cr^+$

12. Which of the glycosidic linkage between galactose and glucose is present in lactose?

- (1) C-1 of galactose and C-4 of glucose
- (2) C-1 of glucose and C-6 of galactose
- (3) C-1 of glucose and C-4 of galactose
- (4) C-1 of galactose and C-6 of glucose

13. Compound(s) which will liberate carbon dioxide with sodium bicarbonate solution is/are:

“Knowledge Is The Best Investment”

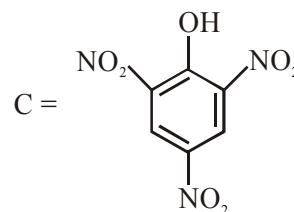
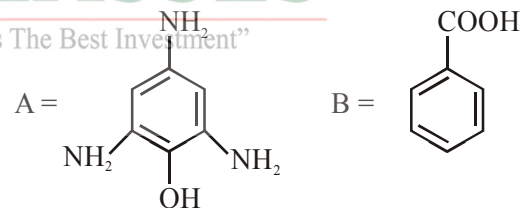

- (1) B only
- (2) C only
- (3) B and C only
- (4) A and B only

14. The hybridization and magnetic nature of  $[Mn(CN)_6]^{4-}$  and  $[Fe(CN)_6]^{3-}$ , respectively are:

- (1)  $d^2sp^3$  and diamagnetic
- (2)  $sp^3d^2$  and diamagnetic
- (3)  $d^2sp^3$  and paramagnetic
- (4)  $sp^3d^2$  and paramagnetic



15. Ellingham diagram is a graphical representation of:  
 (1)  $\Delta H$  vs T (2)  $\Delta G$  vs T  
 (3)  $\Delta G$  vs P (4)  $(\Delta G - T\Delta S)$  vs T
16. The solubility of AgCN in a buffer solution of pH = 3 is x. The value of x is:  
 [Assume : No cyano complex is formed;  $K_{sp}(\text{AgCN}) = 2.2 \times 10^{-16}$  and  $K_a(\text{HCN}) = 6.2 \times 10^{-10}$ ]  
 (1)  $0.625 \times 10^{-6}$  (2)  $1.9 \times 10^{-5}$   
 (3)  $2.2 \times 10^{-16}$  (4)  $1.6 \times 10^{-6}$

17. In Freundlich adsorption isotherm at moderate pressure, the extent of adsorption  $\left(\frac{x}{m}\right)$  is directly proportional to  $P^x$ . The value of x is  
 (1) zero (2)  $\frac{1}{n}$   
 (3) 1 (4)  $\infty$

18. Identify A and B in the chemical reaction.

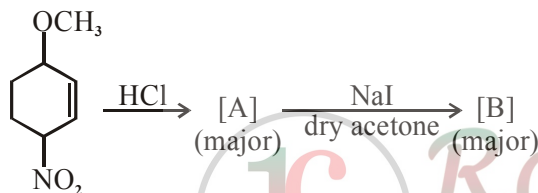

- (1) A = B =
- (2) A = B =
- (3) A = B =
- (4) A = B =

19. Which statement is correct ?

- (1) Synthesis of Buna-S needs nascent oxygen.  
 (2) Neoprene is an addition copolymer used in plastic bucket manufacturing.  
 (3) Buna-S is a synthetic and linear thermosetting polymer.  
 (4) Buna-N is a natural polymer.

20. The major product of the following chemical reaction is :

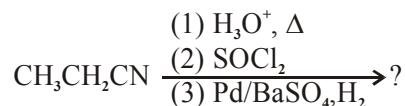

- (1)  $\text{CH}_3\text{CH}_2\text{CH}_3$  (2)  $\text{CH}_3\text{CH}_2\text{CH}_2\text{OH}$   
 (3)  $(\text{CH}_3\text{CH}_2\text{CO})_2\text{O}$  (4)  $\text{CH}_3\text{CH}_2\text{CHO}$

### SECTION-B

1. Among the following, the number of halide(s) which is/are inert to hydrolysis is \_\_\_\_\_.  
 (A)  $\text{BF}_3$  (B)  $\text{SiCl}_4$   
 (C)  $\text{PCl}_5$  (D)  $\text{SF}_6$
2. 1 molal aqueous solution of an electrolyte  $\text{A}_2\text{B}_3$  is 60% ionised. The boiling point of the solution at 1 atm is \_\_\_\_\_ K. (Rounded-off to the nearest integer)  
 [Given  $K_b$  for  $(\text{H}_2\text{O}) = 0.52 \text{ K kg mol}^{-1}$ ]
3. In basic medium  $\text{CrO}_4^{2-}$  oxidises  $\text{S}_2\text{O}_3^{2-}$  to form  $\text{SO}_4^{2-}$  and itself changes into  $\text{Cr}(\text{OH})_4^-$ . The volume of 0.154 M  $\text{CrO}_4^{2-}$  required to react with 40 mL of 0.25 M  $\text{S}_2\text{O}_3^{2-}$  is \_\_\_\_\_ mL. (Rounded-off to the nearest integer)
4. A car tyre is filled with nitrogen gas at 35 psi at  $27^\circ\text{C}$ . It will burst if pressure exceeds 40 psi. The temperature in  $^\circ\text{C}$  at which the car tyre will burst is \_\_\_\_\_. (Rounded-off to the nearest integer)



5. The reaction of cyanamide,  $\text{NH}_2\text{CN}_{(s)}$  with oxygen was run in a bomb calorimeter and  $\Delta U$  was found to be  $-742.24 \text{ kJ mol}^{-1}$ . The magnitude of  $\Delta H_{298}$  for the reaction

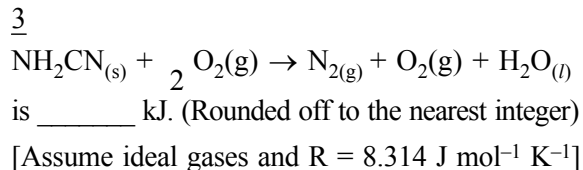

6. Using the provided information in the following paper chromatogram :

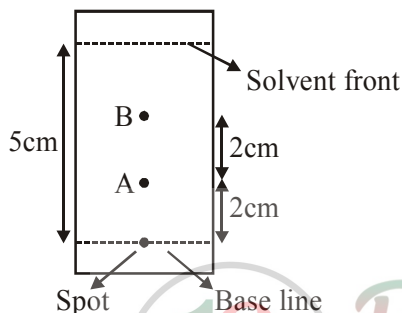
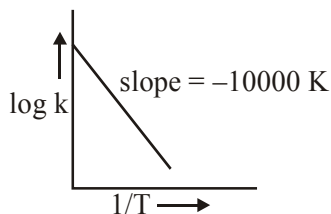

Figure : Paper chromatography for compounds A and B.

the calculate  $R_f$  value of A \_\_\_\_\_  $\times 10^{-1}$ .

7. For the reaction,  $aA + bB \rightarrow cC + dD$ , the plot

of  $\log k$  vs  $\frac{1}{T}$  is given below :



The temperature at which the rate constant of the reaction is  $10^{-4} \text{ s}^{-1}$  is \_\_\_\_\_ K.

(Rounded-off to the nearest integer)

[Given : The rate constant of the reaction is  $10^{-5} \text{ s}^{-1}$  at 500 K.]

8. 0.4 g mixture of  $\text{NaOH}$ ,  $\text{Na}_2\text{CO}_3$  and some inert impurities was first titrated with  $\frac{N}{10}$   $\text{HCl}$  using phenolphthalein as an indicator, 17.5 mL of  $\text{HCl}$  was required at the end point. After this methyl orange was added and titrated. 1.5 mL of same  $\text{HCl}$  was required for the next end point. The weight percentage of  $\text{Na}_2\text{CO}_3$  in the mixture is \_\_\_\_\_. (Rounded-off to the nearest integer)

9. Consider the following chemical reaction.

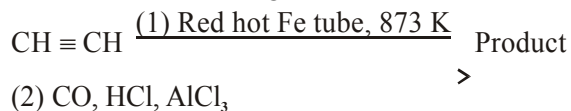

The number of  $\text{sp}^2$  hybridized carbon atom(s) present in the product is \_\_\_\_\_.

10. The ionization enthalpy of  $\text{Na}^+$  formation from  $\text{Na}_{(g)}$  is  $495.8 \text{ kJ mol}^{-1}$ , while the electron gain enthalpy of  $\text{Br}$  is  $-325.0 \text{ kJ mol}^{-1}$ . Given the lattice enthalpy of  $\text{NaBr}$  is  $-728.4 \text{ kJ mol}^{-1}$ . The energy for the formation of  $\text{NaBr}$  ionic solid is  $(-)$  \_\_\_\_\_  $\times 10^{-1} \text{ kJ mol}^{-1}$ .

# MATHEMATICS

## SECTION-A

1. When a missile is fired from a ship, the probability that it is intercepted is  $\frac{1}{3}$  and the probability that the missile hits the target, given that it is not intercepted, is  $\frac{3}{4}$ . If three missiles are fired independently from the ship, then the probability that all three hit the target, is :
- (1)  $\frac{1}{27}$       (2)  $\frac{3}{4}$       (3)  $\frac{1}{8}$       (4)  $\frac{3}{8}$
2. If  $0 < \theta, \phi < \frac{\pi}{2}$ ,  $x = \sum_{n=0}^{\infty} \cos^{2n} \theta$ ,  $y = \sum_{n=0}^{\infty} \sin^{2n} \phi$  and  $z = \sum_{n=0}^{\infty} \cos^{2n} \theta \cdot \sin^{2n} \phi$  then :
- (1)  $xy - z = (x + y)z$   
 (2)  $xy + yz + zx = z$   
 (3)  $xyz = 4$   
 (4)  $xy + z = (x + y)z$
3. Let  $f, g : \mathbb{N} \rightarrow \mathbb{N}$  such that  $f(n + 1) = f(n) + f(1) \forall n \in \mathbb{N}$  and  $g$  be any arbitrary function. Which of the following statements is NOT true?
- (1) If  $f \circ g$  is one-one, then  $g$  is one-one  
 (2) If  $f$  is onto, then  $f(n) = n \forall n \in \mathbb{N}$   
 (3)  $f$  is one-one  
 (4) If  $g$  is onto, then  $f \circ g$  is one-one
4. The equation of the line through the point  $(0,1,2)$  and perpendicular to the line  $\frac{x-1}{2} = \frac{y+1}{3} = \frac{z-1}{-2}$  is :
- (1)  $\frac{x}{3} = \frac{y-1}{4} = \frac{z-2}{3}$   
 (2)  $\frac{x}{3} = \frac{y-1}{-4} = \frac{z-2}{3}$   
 (3)  $\frac{x}{3} = \frac{y-1}{4} = \frac{z-2}{-3}$   
 (4)  $\frac{x}{-3} = \frac{y-1}{4} = \frac{z-2}{3}$
5. Let  $\alpha$  be the angle between the lines whose direction cosines satisfy the equations  $l + m - n = 0$  and  $l^2 + m^2 - n^2 = 0$ . Then the value of  $\sin^4 \alpha + \cos^4 \alpha$  is :
- (1)  $\frac{3}{4}$       (2)  $\frac{3}{8}$       (3)  $\frac{5}{8}$       (4)  $\frac{1}{2}$
6. The value of the integral  $\int \frac{\sin \theta \cdot \sin 2\theta (\sin^6 \theta + \sin^4 \theta + \sin^2 \theta) \sqrt{2 \sin^4 \theta + 3 \sin^2 \theta + 6}}{1 - \cos 2\theta} d\theta$  is: (where  $c$  is a constant of integration)
- (1)  $\frac{1}{18} [11 - 18 \sin^2 \theta + 9 \sin^4 \theta - 2 \sin^6 \theta]^{\frac{3}{2}} + c$   
 (2)  $\frac{1}{18} [9 - 2 \cos^6 \theta - 3 \cos^4 \theta - 6 \cos^2 \theta]^{\frac{3}{2}} + c$   
 (3)  $\frac{1}{18} [9 - 2 \sin^6 \theta - 3 \sin^4 \theta - 6 \sin^2 \theta]^{\frac{3}{2}} + c$   
 (4)  $\frac{1}{18} [11 - 18 \cos^2 \theta + 9 \cos^4 \theta - 2 \cos^6 \theta]^{\frac{3}{2}} + c$
7. The value of  $\int_{-1}^1 x^2 e^{[x^3]} dx$ , where  $[t]$  denotes the greatest integer  $\leq t$ , is :
- (1)  $\frac{e-1}{3e}$       (2)  $\frac{e+1}{3}$       (3)  $\frac{e+1}{3e}$       (4)  $\frac{1}{3e}$
8. A man is observing, from the top of a tower, a boat speeding towards the tower from a certain point A, with uniform speed. At that point, angle of depression of the boat with the man's eye is  $30^\circ$  (Ignore man's height). After sailing for 20 seconds, towards the base of the tower (which is at the level of water), the boat has reached a point B, where the angle of depression is  $45^\circ$ . Then the time taken (in seconds) by the boat from B to reach the base of the tower is:
- (1) 10      (2)  $10\sqrt{3}$   
 (3)  $10(\sqrt{3}+1)$       (4)  $10(\sqrt{3}-1)$

9. A tangent is drawn to the parabola  $y^2 = 6x$  which is perpendicular to the line  $2x + y = 1$ . Which of the following points does NOT lie on it?  
 (1)  $(-6, 0)$  (2)  $(4, 5)$  (3)  $(5, 4)$  (4)  $(0, 3)$

10. All possible values of  $\theta \in [0, 2\pi]$  for which  $\sin 2\theta + \tan 2\theta > 0$  lie in :

- (1)  $\left(0, \frac{\pi}{2}\right) \cup \left(\pi, \frac{3\pi}{2}\right)$   
 (2)  $\left(0, \frac{\pi}{2}\right) \cup \left(\frac{\pi}{2}, \frac{3\pi}{4}\right) \cup \left(\pi, \frac{7\pi}{6}\right)$   
 (3)  $\left(0, \frac{\pi}{4}\right) \cup \left(\frac{\pi}{2}, \frac{3\pi}{4}\right) \cup \left(\frac{3\pi}{2}, \frac{11\pi}{6}\right)$   
 (4)  $\left(0, \frac{\pi}{4}\right) \cup \left(\frac{\pi}{2}, \frac{3\pi}{4}\right) \cup \left(\pi, \frac{5\pi}{4}\right) \cup \left(\frac{3\pi}{2}, \frac{7\pi}{4}\right)$

11. Let the lines  $(2 - i)z = (2 + i)\bar{z}$  and  $(2 + i)z + (i - 2)\bar{z} - 4i = 0$ , (here  $i^2 = -1$ ) be normal to a circle C. If the line  $iz + \bar{z} + 1 + i = 0$  is tangent to this circle C, then its radius is:

- (1)  $\frac{3}{\sqrt{2}}$  (2)  $\frac{1}{2\sqrt{2}}$  (3)  $3\sqrt{2}$  (4)  $\frac{3}{2\sqrt{2}}$

12. The image of the point  $(3, 5)$  in the line  $x - y + 1 = 0$ , lies on :

- (1)  $(x - 2)^2 + (y - 2)^2 = 12$   
 (2)  $(x - 4)^2 + (y + 2)^2 = 16$   
 (3)  $(x - 4)^2 + (y - 4)^2 = 8$   
 (4)  $(x - 2)^2 + (y - 4)^2 = 4$

13. If the curves,  $\frac{x^2}{a} + \frac{y^2}{b} = 1$  and  $\frac{x^2}{c} + \frac{y^2}{d} = 1$

intersect each other at an angle of  $90^\circ$ , then which of the following relations is TRUE?

- (1)  $a + b = c + d$   
 (2)  $a - b = c - d$   
 (3)  $a - c = b + d$   
 (4)  $ab = \frac{c+d}{a+b}$

14.  $\lim_{n \rightarrow \infty} \left( 1 + \frac{1 + \frac{1}{2} + \dots + \frac{1}{n}}{n^2} \right)^n$  is equal to :

- (1)  $\frac{1}{2}$  (2) 0 (3)  $\frac{1}{e}$  (4) 1

15. The coefficients a, b and c of the quadratic equation,  $ax^2 + bx + c = 0$  are obtained by throwing a dice three times. The probability that this equation has equal roots is:

- (1)  $\frac{1}{72}$  (2)  $\frac{5}{216}$  (3)  $\frac{1}{36}$  (4)  $\frac{1}{54}$

16. The total number of positive integral solutions  $(x, y, z)$  such that  $xyz = 24$  is :

- (1) 36 (2) 24 (3) 45 (4) 30

17. The integer 'k', for which the inequality  $x^2 - 2(3k - 1)x + 8k^2 - 7 > 0$  is valid for every  $x$  in  $\mathbb{R}$ , is :

- (1) 3 (2) 2 (3) 0 (4) 4

18. If a curve passes through the origin and the slope of the tangent to it at any point  $(x, y)$  is

$$\frac{x^2 - 4x + y + 8}{x - 2}$$

, then this curve also passes

through the point:

- (1)  $(5, 4)$  (2)  $(4, 5)$  (3)  $(4, 4)$  (4)  $(5, 5)$

19. The statement  $A \rightarrow (B \rightarrow A)$  is equivalent to :

- (1)  $A \rightarrow (A \wedge B)$  (2)  $A \rightarrow (A \rightarrow B)$   
 (3)  $A \rightarrow (A \leftrightarrow B)$  (4)  $A \rightarrow (A \vee B)$

20. If Rolle's theorem holds for the function  $f(x) = x^3 - ax^2 + bx - 4$ ,  $x \in [1, 2]$  with

$f'\left(\frac{4}{3}\right) = 0$ , then ordered pair  $(a, b)$  is equal to :

- (1)  $(5, 8)$  (2)  $(-5, 8)$   
 (3)  $(5, -8)$  (4)  $(-5, -8)$

**SECTION-B**

1. Let  $f(x)$  be a polynomial of degree 6 in  $x$ , in which the coefficient of  $x^6$  is unity and it has extrema at  $x = -1$  and  $x = 1$ . If  $\lim_{x \rightarrow 0} \frac{f(x)}{x^3} = 1$ , then  $5 \cdot f(2)$  is equal to \_\_\_\_\_.

2. The number of points, at which the function  $f(x) = |2x + 1| - 3|x + 2| + |x^2 + x - 2|$ ,  $x \in \mathbb{R}$  is not differentiable, is \_\_\_\_\_.

3. The graphs of sine and cosine functions, intersect each other at a number of points and between two consecutive points of intersection, the two graphs enclose the same area  $A$ . Then  $A^4$  is equal to \_\_\_\_\_.

Let  $A_1, A_2, A_3, \dots$  be squares such that

4. for each  $n \geq 1$ , the length of the side of  $A_n$  equals the length of diagonal of  $A_{n+1}$ . If the length of  $A_1$  is 12 cm, then the smallest value of  $n$  for which area of  $A_n$  is less than one, is \_\_\_\_\_.

5. Let  $A = \begin{bmatrix} x & y & z \\ y & z & x \\ z & x & y \end{bmatrix}$ , where  $x, y$  and  $z$  are real

numbers such that  $x + y + z > 0$  and  $xyz = 2$ . If  $A^2 = I_3$ , then the value of  $x^3 + y^3 + z^3$  is \_\_\_\_\_.

6. If  $A = \begin{bmatrix} 0 & -\tan\left(\frac{\theta}{2}\right) \\ \tan\left(\frac{\theta}{2}\right) & 0 \end{bmatrix}$  and

$(I_2 + A)(I_2 - A)^{-1} = \begin{bmatrix} a & -b \\ b & a \end{bmatrix}$ , then  $13(a^2 + b^2)$  is equal to \_\_\_\_\_.

7. The total number of numbers, lying between 100 and 1000 that can be formed with the digits 1, 2, 3, 4, 5, if the repetition of digits is not allowed and numbers are divisible by either 3 or 5, is \_\_\_\_\_.

8. Let  $\vec{a} = \hat{i} + 2\hat{j} - \hat{k}$ ,  $\vec{b} = \hat{i} - \hat{j}$  and  $\vec{c} = \hat{i} - \hat{j} - \hat{k}$  be three given vectors. If  $\vec{r}$  is a vector such that  $\vec{r} \times \vec{a} = \vec{c} \times \vec{a}$  and  $\vec{r} \cdot \vec{b} = 0$ , then  $\vec{r} \cdot \vec{a}$  is equal to \_\_\_\_\_.

9. If the system of equations

$$kx + y + 2z = 1$$

$$3x - y - 2z = 2$$

$$-2x - 2y - 4z = 3$$

has infinitely many solutions, then  $k$  is equal to \_\_\_\_\_.

10. The locus of the point of intersection of the lines

$$\sqrt{3}kx + ky - 4\sqrt{3} = 0 \text{ and}$$

$$\sqrt{3}x - y - 4(\sqrt{3})k = 0 \text{ is a conic, whose}$$

eccentricity is \_\_\_\_\_.